

# SAWPA

A close-up photograph of a silver fountain pen with a black nib, resting on a document. The document features a line graph with a blue line and a bar chart with a black bar. A magnifying glass is visible on the right side of the image, focusing on the pen's nib. The background is a light blue gradient.

**FYE 2022 and 2023 Budget  
Goals and Objectives**

# Agenda

A close-up photograph of a silver fountain pen nib resting on a document. The document features a line graph with a blue line and handwritten text in blue ink. The background is a dark blue gradient.

1

**Agency Vision**

2

**Brine Line Goals and Objectives**

3

**OWOW Goals and Objectives**

4

**Roundtables Goals and Objectives**

5

**Agency Operations Goals and Objectives**



# The Vision

- Create a sustainable Santa Ana River Watershed that is drought-proofed, salt balanced and supports economic and environmental vitality by the year 2030
- Lead the State in Regional Planning
- Provide leadership in creating innovative and integrated solutions to the challenges facing the watershed





# Achieving the Vision

**Brine Line**

**OWOW**

**Roundtables**

The three major cornerstones of SAWPA's foundation; Brine Line, OWOW and the Roundtables, are essential to achieving SAWPA's vision.



# The Cornerstones

## Brine Line

Designed as the primary method of salt export for the watershed. Removing salt by means of the Brine Line system allows the Watershed to work toward achieving salt balance – a key Watershed goal and indicator of sustainability.

## OWOW

Bringing together water agency officials, government leaders, environmentalists, and businesses to work in an open, collaborative and coordinated effort toward finding solutions to the challenges facing the region's water supply.

## Roundtables

A forum that brings together many agencies and organizations to address and solve a multiplicity of problems through integration and innovation. SAWPA serves as the administrator/facilitator in these many efforts.



# The Cornerstones

Brine Line

OWOW

Roundtables

Agency  
Operations

SAWPA



# Strategic Plan Goals and Objectives



A close-up photograph of a silver fountain pen nib resting on a document. The document features a line graph with a red line and some text, including 'MAY' and 'UR'. A magnifying glass is visible in the upper right corner, focusing on the document. The background is a dark blue gradient.

# Brine Line

- Support the achievement of a long-term watershed-wide salinity balance through:
  - Water quality maintenance, enhancement, and protection in the Santa Ana River and groundwater basins
  - Water resources management, including imported water recharge
  - Disposal of emergency discharges from local wastewater treatment plants
  - Supporting industries limited by salt in their effluent, including energy production facilities
  - Providing existing and future public agencies and private industry with a cost-effective salinity management option



A close-up photograph of a silver fountain pen nib resting on a document. The document features a line graph with a blue line and a calendar grid with months labeled 'Feb.', 'Apr.', and 'Jun.'. The background is a dark blue gradient.

# OWOW

- Fulfill SAWPA's role as a CA IRWM Program Regional Water Management Group and provide for a process of determining IRWM funding that meets statutory requirements
- Prepare a credible integrated watershed-wide water management plan that is updated regularly, meets regional needs and DWR IRWM plan requirements, and provides safe, clean, reliable and affordable water for the SAR Watershed
- Facilitate the discovery and development of new watershed solutions
- Maximize funding opportunities and policy influence by uniting efforts watershed wide



# Roundtables

- Create value by building relationships among regulators, SAWPA members, regulated parties that allow for economies of scale, reduced costs, or increased benefits in addressing water related issues
- Provide regional capacity and neutral venue for supporting multi-agency forum(s) to address the water resources challenges in the SAR Watershed
- Assist in the establishment and on-going facilitation of stakeholder processes to address watershed-specific issues.

A close-up photograph of a silver fountain pen nib resting on a document. The document features a line graph with a red line and some handwritten text in blue ink. The background is a dark blue gradient.

# Agency Operations

- Refine staff capability as regional resources
- Effective and efficient operations
- Legislative advocacy
- Increase digital presence of SAWPA
- Data acquisition, organization, management
- Maximize grant opportunities
- Grant management



# FYE 2022 and 2023 Budget Goals and Objectives



A fountain pen with a silver nib is positioned diagonally across the top of the slide. Below it, a document is visible, featuring a line graph with a red line and some text, including the word 'MAY' and 'APR'. A magnifying glass is partially visible on the right side of the document.

# Brine Line - Operations

- Marketing – update plan, brochure, and implement program
- Implement new capacity lease pool program
- Develop program to use unused capacity owned by SAWPA (17 mgd)
- Pretreatment Program
  - Update program policies and procedures
  - Complete program audit and implement any corrective actions
  - Hire and integrate new employee to replace retiring employee with 30+ years of experience
- Continue to maintain/grow partnership with OCSD
  - Joint Operations Committee
  - Joint Policy Committee
- Complete Brine Line Business Plan and implement recommendations



# Brine Line - Operations

- Continue O&M Programs
  - Line cleaning and inspection
  - MAS Inspections
  - A / V valves – frequent maintenance, containment, alarm
- Update financial model to determine Brine Line rates
- Complete the 2-year audit of the Sewer System Management Plan
- Update/refine safety plan and training
- Increase in-house field staff capability/equipment reducing reliance on contractors, increasing efficiency, reducing costs
- Continue coordination with outside contractors working near the Brine Line to reduce risk of SSO's

A close-up photograph of a silver fountain pen nib resting on a document. The document features a line graph with a red line and handwritten text in blue ink. The background is a dark blue gradient.

# Brine Line – Operations

- Evaluate impacts of technology on Brine Line operations
  - Improved RO efficiency
  - Zero liquid discharge
  - Indirect potable reuse
- Address corrosion protection issues on Reach 4A Upper
- Replace Reach 5 blow-off and air release vacuum isolation valves in coordination with EMWD Brine Line lateral project

A close-up photograph of a silver fountain pen nib resting on a document. The document features a line graph with a red line and some handwritten text in blue ink. The background is a soft, out-of-focus blue.

# Brine Line - Capital Projects

- Reach 4D corrosion repairs
  - Commence mid-term pipe inspection as recommended in the 2018 Reach 4D condition assessment
  - Line cleaning
  - CCTV and in-pipe inspection of 7-mile section
- Coordinate with City of Chino and Caltrans on the new Hwy 71 / Pine Avenue Off-ramp impacts
  - Complete protection/relocation of the Pine Avenue siphon and a portion of the Reach 4A Upper Brine Line
- Complete sealing of maintenance access structures within the Prado Basin Inundation area below elevation of 556 feet



A close-up photograph of a silver fountain pen nib resting on a document. The document features a line graph with a red line and some handwritten text in blue ink. The background is a soft, out-of-focus blue.

# Brine Line - Capital Projects

- Complete evaluation of Reach 5 pipeline within Baker Street, City of Lake Elsinore due to erosion within unpaved roadway
- Conduct Reach 4 pipeline inspection and condition study
- Perform Reach 4B ductile iron pipe inspection and condition study
- Relocate Reach 5 air vacs (25) to underground location
- Repair and line upper Reach 4A maintenance access structures
- Coordinate with Riverside County Transportation Department
  - Widening of Temescal Canyon Road (El Cerrito Segment)
  - Relocating air vac valves
  - Potential protecting/relocating Reach 5 pipeline

A close-up photograph of a silver fountain pen nib resting on a document. The document features a line graph with a red line and some text, including the word 'UR' and 'MAY'. A magnifying glass is partially visible in the upper right corner. The background is a dark blue gradient.

# OWOW

- Fund 373 OWOW Plan
- Fund 370-01 General Basin Planning
- Fund 370-02 USBR Partnership Studies
- Fund 135 and 145 Proposition 84 - Grant Administration
- Fund 150 Proposition 1 – Grant Administration
- Fund 504-401 Proposition 84 - 2015 Round SARCCUP – PA23 Committee
- Fund 505 – Proposition 1 Grant Projects



# Fund 373 OWOW Plan

Project Manager: Ian Achimore

Funding Source: Member Agency Contributions and Proposition 1 - IRWM Planning Grant

- Fulfill SAWPA's role as a state-approved Regional Water Management Group in the Integrated Regional Water Management Program
- Provide watershed coordination to support implementation of the OWOW Plan Update 2018
- Administer the OWOW Integrated Regional Water Management Proposition 1 Round 2 implementation grant program
- Plan and hold an OWOW conference in the spring of 2022



# Fund 370-01 General Basin Planning

Project Manager: Mark Norton

Funding Source: Member Agency Contributions, Participant Fees, and Proposition 1 – IRWM Round 2 Grant

- Conduct planning activities that focus on inter-agency coordination and cooperation, integration within the member agencies and external organizations
- Coordinate with Regional Board staff (monthly) and attend Regional Board meetings (quarterly)
- Prepare any new grant applications to support SAWPA mission
- Santa Ana River Trail Technical Advisory Committee
- Represent SAWPA and region in addressing salinity issues through participation in So Cal Salinity Coalition (SCSC)
- Prepare weather modification ground site locations analysis, CEQA, and implement first year of three-year pilot program





# Fund 370-02 USBR Partnership Studies

Project Manager: Mark Norton

Funding Source: Member Agency Contributions, USBR Grant funding

- Coordinate and prepare possible grant funding partnership with the US Bureau of Reclamation programs such as Water Smart and Basin Studies update program
- Monitor and, if deemed necessary and beneficial, develop and prepare Reclamation grant applications
- Administer any successful grant programs with Reclamation staff
- Conduct coordination with Reclamation staff on joint programs of merit and benefit to the watershed
- Conduct consultant contract administration including RFP, agreements, task orders, and general oversight and review

A close-up photograph of a silver fountain pen nib resting on a document. The document features a line graph with a red line and some text, including the word 'MAY' and 'UR'. A magnifying glass is visible in the upper right corner, focusing on the document. The background is a dark blue gradient.

# Funds 135 and 145 Proposition 84 – Grant Administration

Project Manager: David Ruhl

Funding Source: Proposition 84 Grant Funding

- Continue grant administration for Proposition 84
  - Round 2
  - Final (2015) Round

A close-up photograph of a silver fountain pen nib resting on a document. The document features a line graph with a blue line and handwritten text in blue ink. The background is a dark blue gradient.

# Fund 150 Proposition 1 – Grant Administration

Project Manager: David Ruhl

Funding Source: Proposition 1 Grant Funding

- Administer the Proposition 1 Grant Program



# Fund 504-401 Proposition 84 - Final Round Projects

Project Manager: Ian Achimore

Funding Source: Proposition 84 Grant Funding

- Administer PA23 Committee
- Implement SARCCUP
- Complete SARCCUP Water Use Efficiency Budget Assistance Project



A close-up photograph of a silver fountain pen nib resting on a document. The document features a line graph with a red line and some text, including the word 'WATER' and 'UR'. A magnifying glass is visible in the upper right corner, focusing on the document. The background is a dark blue gradient.

# Fund 505 Proposition 1 – Capital Projects

Project Manager: Ian Achimore

Funding Source: Proposition 1 Grant Funding

- Administer grant program
- Develop and implement demand reduction and water use efficiency measures
- Work with US Bureau of Reclamation to analyze high resolution imagery of the watershed
- Develop and finalize water efficiency budgets based on the imagery analysis

A close-up photograph of a silver fountain pen nib resting on a document. The document features a line graph with a blue line and handwritten text in blue ink. The background is a dark blue gradient.

# Roundtables

- Fund 374 Basin Monitoring Program TF
- Fund 381 SAR Fish Conservation TF
- Fund 384-01 MSAR TMDL TF
- Fund 386 RWQ Monitoring TF
- Fund 387 Arundo Management & Habitat Restoration
- Fund 392 Emerging Constituents TF
- Fund 477 LESJWA JPA Administration

A fountain pen with a silver nib is positioned diagonally across the top of the slide. Below it, a document is visible, featuring a line graph with a red line and some text. A magnifying glass is partially visible on the right side of the document. The background is a dark blue gradient.

# Fund 374 Basin Monitoring Program TF

Project Manager: Mark Norton

Funding Source: Participant Fees

- Administer all defined responsibilities and activities under the Regional Board Basin Plan as defined in the Basin Monitoring Program Task Force agreement
- Prepare and submit updated SAR Annual Water Quality Report to regional board
- Prepare and submit Triennial Ambient Water Quality program design update
- Submit new and revised surface water monitoring program for evaluation compliance (2022)
- Implement study to identify and quantify causes of TDS exceedances
- Evaluate existing Salt Nutrient Management Plan and prepare Basin Plan amendments to align with the 2019 State Board Recycled Water Policy

A fountain pen with a silver nib is positioned diagonally across the top of the slide. Below the pen, a document is visible, featuring a line graph with a red line and some text, including the word 'MAY'. A magnifying glass is partially visible on the right side of the document.

# Fund 381 Santa Ana River Fish Conservation TF

Project Manager: Ian Achimore

Funding Source: Participant Fees and Member Agency Contributions

- Administer SAR Fish Conservation Task Force
- Serve as clearinghouse and coordination body on Santa Ana sucker habitat restoration projects
- Maintain Habitat and Beneficial Use Enhancement Project
- Pursue grants or partnerships to construct additional habitat
- Complete CEQA, permitting and construction for additional habitat
- Gather habitat data based on Santa Ana Riverwalk monitoring
- Coordinate with US Fish and Wildlife and other partners to compare Riverwalk sucker habitat data
- Support permit compliance for OCWD





# Fund 384-01 Middle Santa Ana River TMDL TF

Project Manager: Rick Whetsel

Funding Source: Participant Fees

- Administer MSAR TMDL Task Force
- Conduct 2021–22 and 2022–23 Annual Watershed-wide TMDL compliance monitoring
- Revise and update the Middle Santa Ana River TMDLs
- Develop formal criteria to identify and quantify uncontrollable sources of bacteria
- Support comprehensive bacteria reduction plan (CBRP) implementation



# Fund 386 Regional Water Quality Monitoring TF

Project Manager: Rick Whetsel  
Funding Source: Participant Fees

- Administer Regional Water Quality Monitoring Task Force
- Implement the 2021 and 2022 SAR Bacteria Monitoring Program
  - Monitoring and surveillance requirements of the 2012 adopted Basin Plan Amendment
  - Conduct sampling to support implementation of MSAR Bacteria Indicator TMDL
- Implement Phase 1A (2022) and 1B (2023) homeless encampment water quality and riparian habitat impacts monitoring program
- Amend Basin Plan to address the recalculation of Antidegradation Targets for bacteria



# Fund 387 Arundo Mgmt & Habitat Restoration

Project Manager: Ian Achimore

Funding Source: Mitigation Credit Sales (Proposition 13)

- Administer Santa Ana River Mitigation Bank with Riverside County Parks
  - Coordinate to ensure SAWPA units in Mitigation Bank are sold
  - Improve bank so it mitigates CA Fish & Game Code Section 1600 impacts
- Lead implementation of Arundo donax removal in 300-acre area in Santa Ana River Watershed Headwaters
- Plan and Implement future Arundo Removal and Habitat Restoration Projects

A fountain pen with a silver nib is positioned over a document. The document features a line graph with a red line and some text, including the word 'MAY' and 'UR'. A magnifying glass is visible in the upper right corner, focusing on the document. The background is a dark blue gradient.

# Fund 392 Emerging Constituents TF

Project Manager: Mark Norton

Funding Source: Participant Fees

- Administer all defined responsibilities and activities under the Emerging Constituent Program TF agreement including data collection, data management, and communication and outreach on the safety of tap water.
- Monitor State Board studies and possible further monitoring requirements for ecosystem impacts from ECs, including PFAS
- Administer “Your So Cal Tap Water” and other social media tools





# Fund 477 LESJWA JPA Administration

Project Manager: Mark Norton (JPA )  
Rick Whetsel (TMDL TF)

Funding Source: Reimbursement from LESJWA and minimal member agency contributions

- Administer the LESJWA JPA – serve as authority administrator for LESJWA including all defined responsibilities and activities under the LESJWA JPA and Business Plan
  - Bi-monthly meetings
- Administer the Lake Elsinore & Canyon Lake Nutrient TMDL Task Force
  - Monthly meetings

A close-up photograph of a silver fountain pen nib resting on a document. The document features a line graph with a red line and some text, including the word 'MAY' and 'UR'. A magnifying glass is visible in the upper right corner, partially overlapping the document. The background is a dark blue gradient.

# Agency Operations

- Update strategic plan and implement goals and objectives from the plan
- Improve operation efficiency and effectiveness
- Continue lobbying efforts
- Provide administrative and technology support to Engineering and Planning projects
- Review and improve IT vendor support
- Operate SAWPA hardware, software, and network application needs in an efficient and reliable manner, including remote work environment
- Continue to maximize GIS data investments by providing GIS Web Apps and provide input to local and State initiatives



# Agency Operations

- Improve SAWPA website for accessibility issues
- Improve network security
  - Threat testing
  - Internal phishing campaigns
- GASB 45 and 68 Compliance
  - Actuarial Valuation (FYE 2023)
  - CalPERS Unfunded Liability Disclosure
- Submit Budget and CAFR for GFOA Award Program
- Continue risk transfer protocol review in accordance with Joint Powers Insurance Authority (JPIA) standards
  - Consider joining ACWA JPIA for insurance needs (2023)

A close-up photograph of a silver fountain pen nib resting on a document. The document features a line graph with a red line and some text, including the word 'MAY' and 'UR'. A magnifying glass is partially visible in the upper right corner. The background is a dark blue gradient.

# Agency Operations

- Continue agency-wide transparency commitment and open governance policies applicable to Special District Leadership Foundation (SDLF) transparency certification
- Continue analysis of current policies and procedures to ensure continuity and efficiency; revise as warranted
  - Human Resources
  - Conflict of Interest law
  - FPPC filings
- Document and implement the new Retention and Destruction of Agency Records Policy



A close-up photograph of a silver fountain pen nib resting on a document. The document features a line graph with a red line and some handwritten text in blue ink. The background is a dark blue gradient.

# Agency Operations

- Review and revise workflow process and procedures in contracts and task order preparation
- Consider potential beneficial uses for SAWPA properties such as trails or community gardens



**Questions?**

# Memorandum of Understanding for WECAN Expansion in the City of Riverside

Ian Achimore, Senior Watershed Manager  
SAWPA Commission | January 19, 2021  
Item No. 6.D.



# Recommendation

Authorize the General Manager to execute a Memorandum of Understanding between SAWPA and Riverside Public Utilities for SAWPA to accept cost share from the utility in the amount of \$100,000 to expand the turf removal component of the WECAN program into Riverside.



WATER | ENERGY | LIFE



PUBLIC UTILITIES



# Water Energy Community Action Network (WECAN) - Previous Phases

- ▶ SAWPA partners with retail water agency (4 agencies to date) and hires landscape contractor;
- ▶ SAWPA ensures landscape contractor:
  - ▶ Provides landscaping design choices to residents,
  - ▶ Removes existing turf grass in residential front yards,
  - ▶ Plants drought tolerant landscaping and installs efficient irrigation, and
  - ▶ Conducts post-installation site visits.
- ▶ Phases 1 and 2 of WECAN funded by:
  - ▶ 2014 Water-Energy Nexus Grant (Department of Water Resources), and
  - ▶ 2016 Water and Energy Efficiency Grant (Bureau of Reclamation).



ANAHEIM PUBLIC UTILITIES

**West Valley  
Water District**



**Jurupa**  
Community Services District



# WE CAN



Water Energy  
Community Action  
Network

# 2020 Transformative Climate Communities (TCC) Grant Application to Strategic Growth Council



Projects  Funded



Transportation & Sustainable Communities



Clean Energy & Energy Efficiency



Natural Resources & Waste Diversion



# 2020 TCC Grant Application - Overall Project in Partnership with Riverside

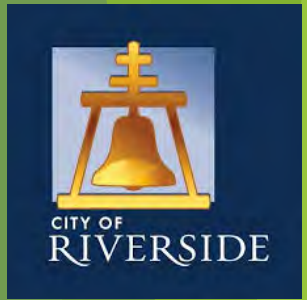

Urban Greening



Solar



Water Conservation



Transit Options



Housing: 7<sup>th</sup> and Chicago Entrada Project







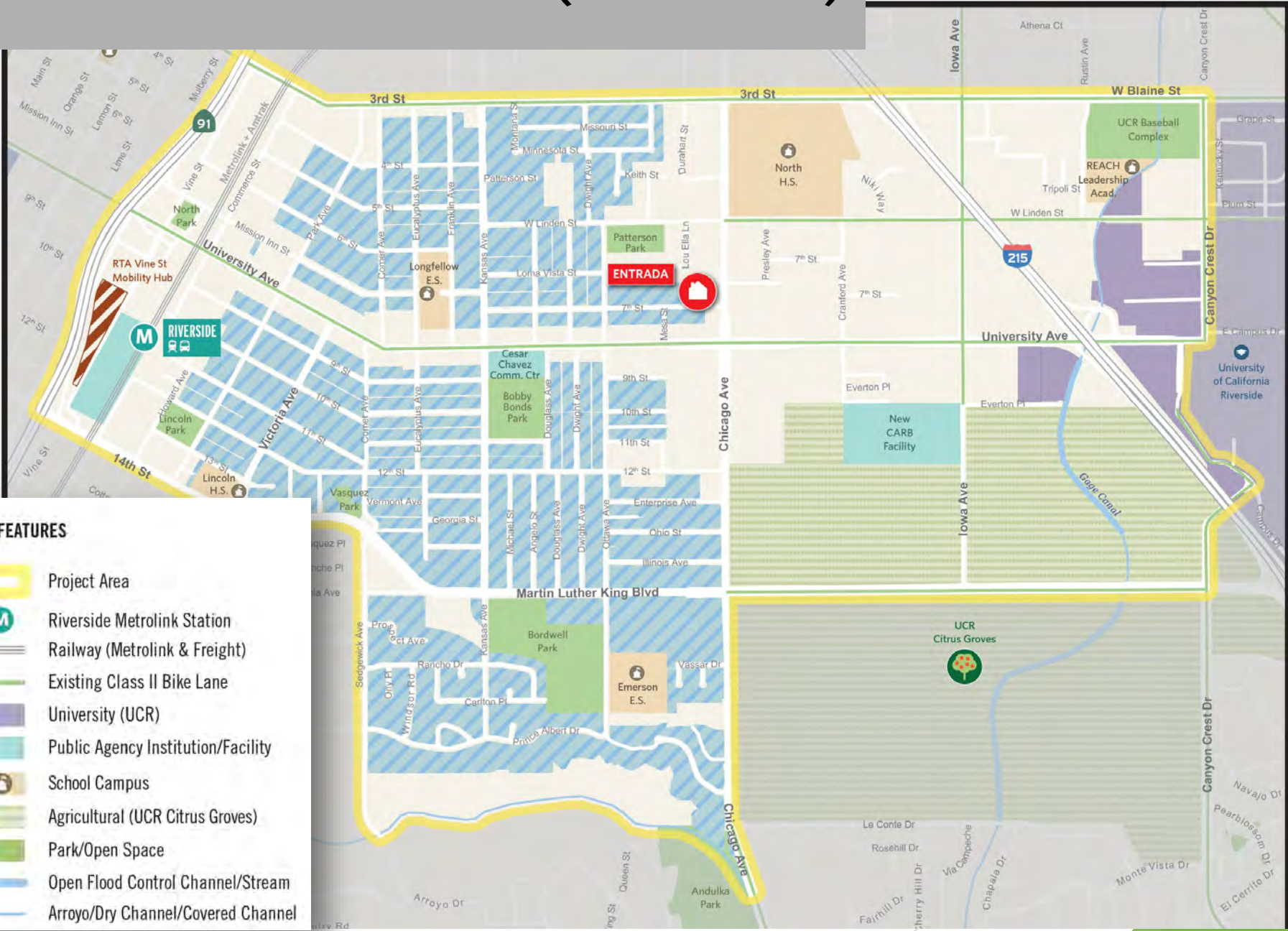







# Project Area - Riverside (Eastside)



### MAP FEATURES

-  Project Area
-  Riverside Metrolink Station
-  Railway (Metrolink & Freight)
-  Existing Class II Bike Lane
-  University (UCR)
-  Public Agency Institution/Facility
-  School Campus
-  Agricultural (UCR Citrus Groves)
-  Park/Open Space
-  Open Flood Control Channel/Stream
-  Arroyo/Dry Channel/Covered Channel

# Previous SAWPA Commission Actions related to WECAN and Riverside

Date	Commission Action
May 2018	Approves MOU with Riverside Housing Authority related to Disadvantaged Communities involvement
October 2018	Approves initial 2018 TCC* grant application and project MOU with City of Riverside
February 2020	Approves Participate Agreement for 2020 TCC grant application
January 2021	Consider MOU with Riverside Public Utilities to accept \$100,000 cost share to implement 2020 TCC grant

\*TCC = Transformative Climate Communities

# City of Riverside – SAWPA WECAN Component

- ▶ Will target 100 single family residential properties for 1,000 square feet of turf removal per home (total of 100,000 square feet); and
- ▶ Will save 11,176 kWh per year from reducing groundwater pumping.

## WECAN Budget

Item	Grant	Match*
Project Management	\$72,000	\$ -
Turf Removal Contractor	\$500,000	\$100,000
Outreach Material	\$21,000	\$ -
Total	\$593,000	\$100,000

\*Provided by Riverside Public Utilities  
Total Cost = \$693,000

# City of Riverside - SAWPA WECAN Component

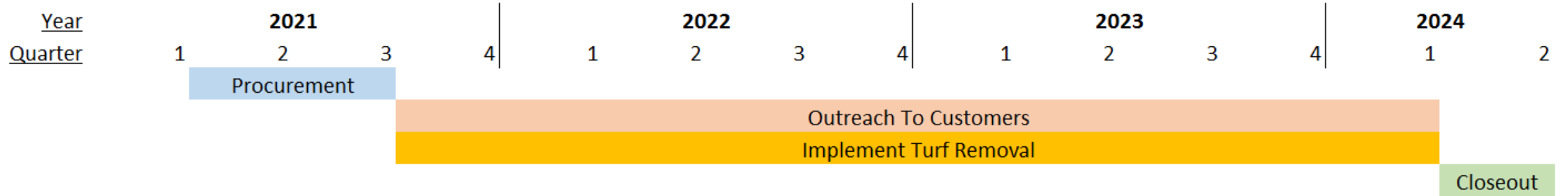



# Provisions of RPU-SAWPA MOU

- ▶ RPU provides SAWPA \$100,000, coordinates on outreach to customers in project area, maintains project records as required by TCC grant;
- ▶ SAWPA utilizes \$100,000 for its turf removal and landscaping contractor to replace 100,000 square feet of landscaping;
- ▶ SAWPA returns any unused funds to RPU at the end of the project term; and
- ▶ SAWPA has its landscaping contractor collect a \$100 deposit from each participating WECAN customer.

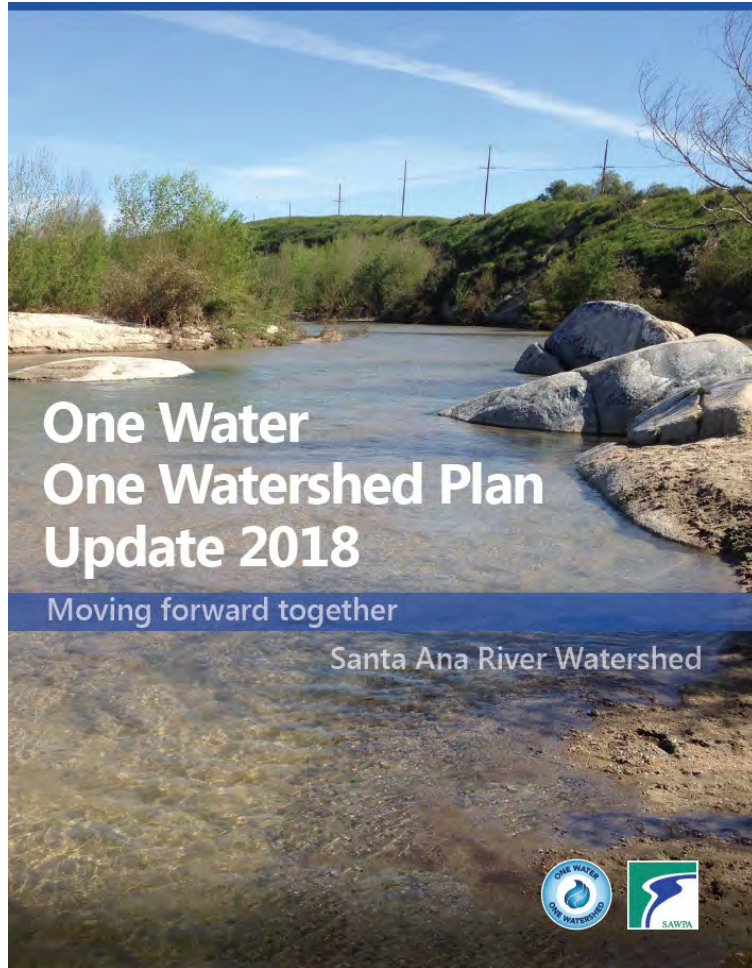

# Benefits of Executing the MOU

- ▶ Furthers a partnership with the City of Riverside, a member on the OWOW Steering Committee;
- ▶ Implements May 2018 MOU between SAWPA and the City of Riverside Housing Authority;
- ▶ Allows SAWPA to implement the OWOW Plan Update 2018 goals of engaging disadvantaged communities and implementing water conservation; and
- ▶ Allows watershed to attain water-energy nexus benefits of saving 13.5 acre-feet per year and 11,176 kWh per year.

# Recommendation

Authorize the General Manager to execute a Memorandum of Understanding between SAWPA and Riverside Public Utilities for SAWPA to accept cost share from the utility in the amount of \$100,000 to expand the turf removal component of the WECAN program into Riverside.



WATER | ENERGY | LIFE



PUBLIC UTILITIES



# Santa Ana River Mitigation Bank Evaluation - Request for Quotes

Ian Achimore | Senior Watershed Manager  
January 19, 2021 | Commission Meeting  
Item 6.E.





# Quick Stats on the Arundo Roundtable

- Arundo Management & Habitat Restoration Fund (Fund) in SAWPA Budget,
- Fund in Budget gains revenue from Santa Ana River Mitigation Bank credit sales,
- Per SAWPA Resolution No. 427, use of the Fund (like a task order) needs to be approved by Commission even if below General Manager signing authority.

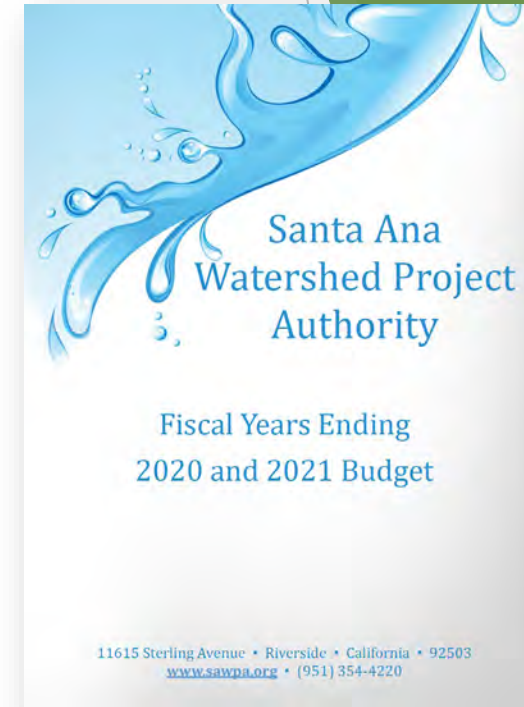

# What is Arundo donax?

- ▶ Invasive Plant (High Rating),
- ▶ Noxious Weed,
- ▶ Uses 3 times amount of water than native vegetation,
- ▶ Highly combustible,
- ▶ Survives fire and thrives,
- ▶ Causes flooding by altering flow regimes, and
- ▶ No known habitat benefit.



# How the Mitigation Bank Works



- ▶ Operated by Riverside County Regional Park and Open-Space District,
- ▶ Created in 1996 with U.S. Army Corps of Engineers (USACE),
- ▶ Mitigates for Clean Water Action Section 404 Impacts (a U.S. Army Corps federal requirement)
- ▶ SAWPA purchased 100 units in 2002 as part of Proposition 13 (2000 Water Bond)
  - ▶ SAWPA purchased units not to mitigate for specific projects, but to invest and gain eventual revenue from credit sales to permittees.

# SAWPA's Involvement in Bank

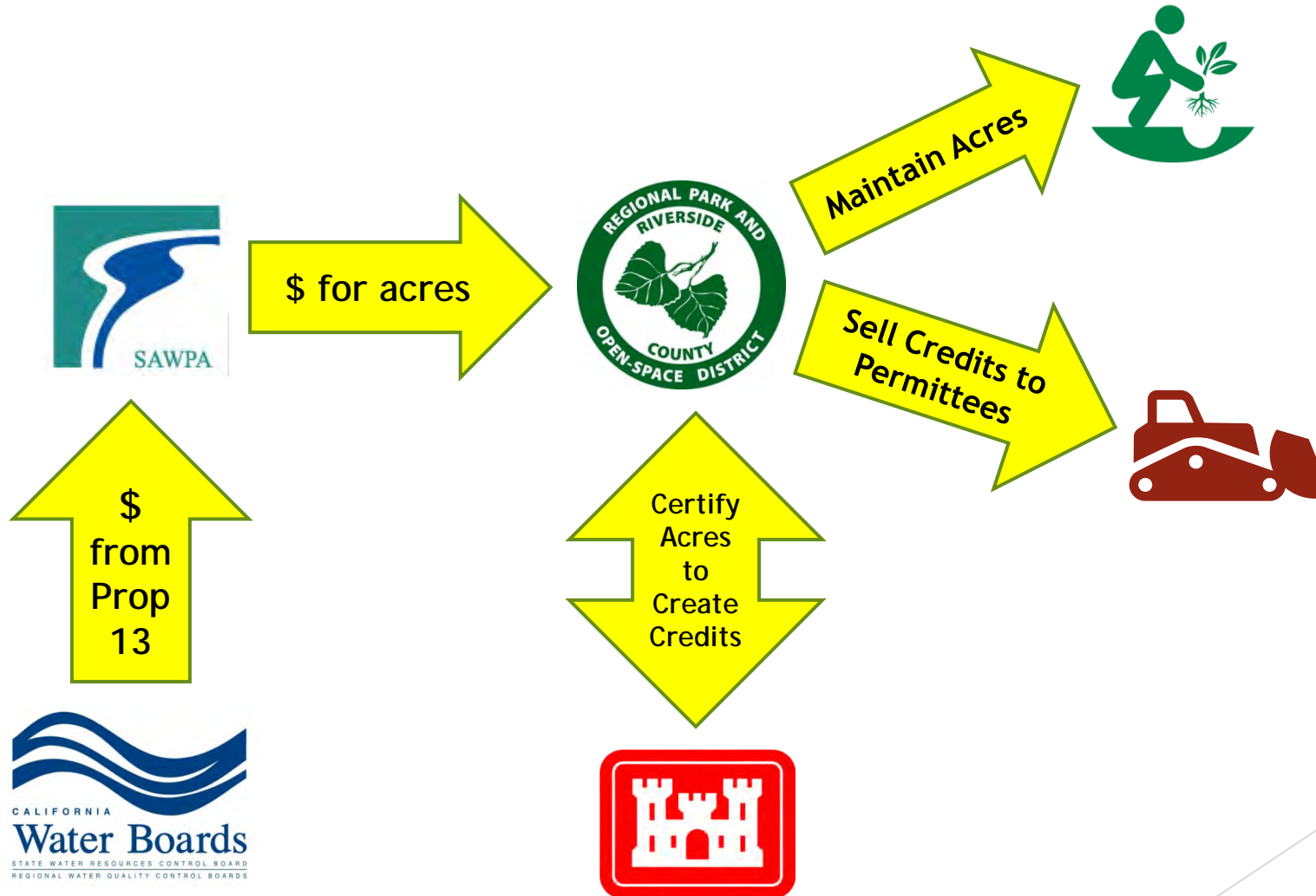



# Bank Revenue Provided to SAWPA

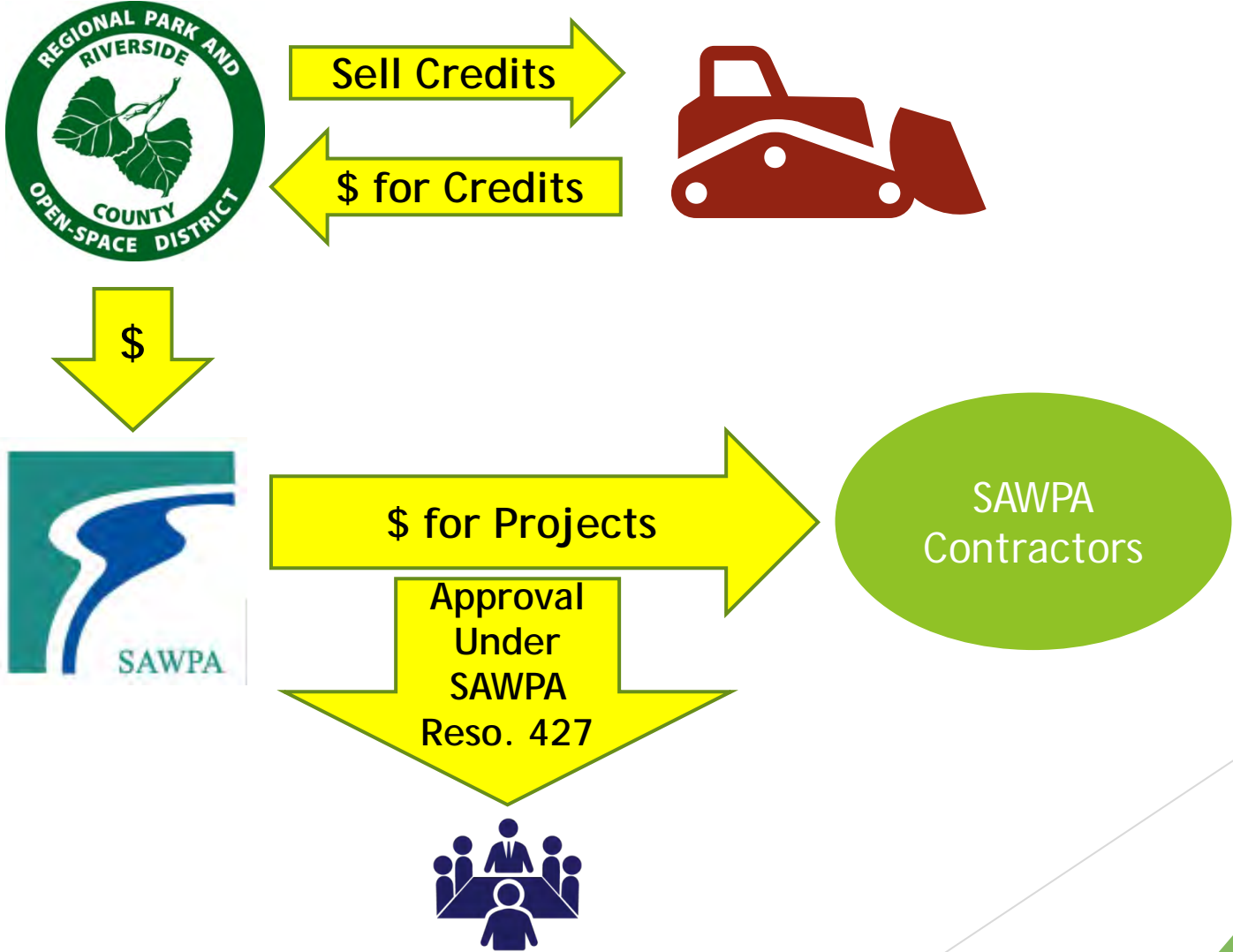

# Permittees Purchase Bank Credits for Areas of a Stream They Impact

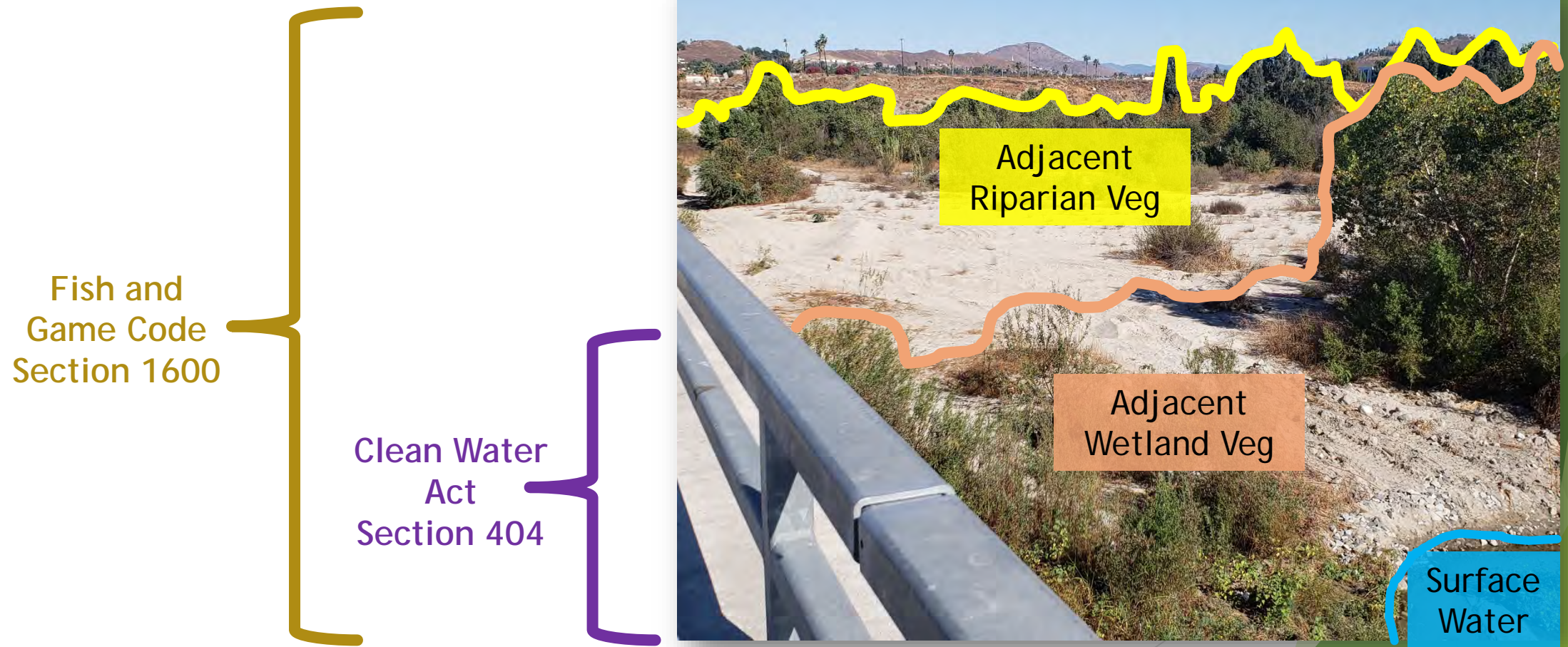

● State Requirement

● Federal Requirement

# Bank Only Covers Federal Clean Water Act Section 404 Impacts



- ▶ Bank exists due to 1996 agreement with U.S. Army Corps of Engineers, the federal agency regulating Clean Water Act Section 404
- ▶ But many project proponents, like cities improving bridge crossings, impact all portions of a stream
- ▶ There are other mitigation bank options in the Santa Ana River Watershed that mitigate for both federal and state stream impacts and
- ▶ SAWPA and Riverside County Parks have discussed issue with State regulatory agency - California Department of Fish and Wildlife (CDFW).

# Status of Credits in the Bank

	Riverside Parks	SAWPA	Total
Credit Total	121.930	100.000	221.930
Credits Sold	93.970	52.236	146.206
Credits Remaining	27.960	47.764	75.724

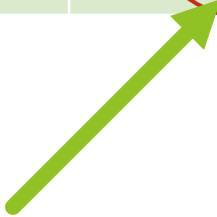

Represents potential revenue to SAWPA  
of \$2,125,020 (or \$44,490 per credit)



# Recommended Approach for Improving Banking Process

- ▶ CDFW recommends a “permittee responsible approach,”
  - ▶ Bank would not be formally certified by CDFW under their mitigation banking policy because that approach would be too costly.
- ▶ Instead, the existing structure (i.e. the acres set aside by Riverside County Parks for enhancement) and Riverside County Parks’ experience in selling credits and maintaining riparian habitat would be leveraged to sell acres.

# Consultant Support Needed to Vet “Permittee Responsible Approach”

Riverside County Parks and SAWPA developed consultant scope to:

- A. Develop cost estimates for all components necessary for Riverside County Parks to implement a “permittee responsible” approach.
- B. Provide analysis of other prices permittees currently pay for Section 1600 and Section 404 mitigation.
- C. Make recommendations on price per unit for acres that satisfy Section 1600 impacts (in addition to Section 404 impacts).

# Procurement Process and SAWPA Resolution Related to Arundo Fund

- ▶ SAWPA received three quotes/responses to comply with the February 2020 SAWPA procurement policy, and
- ▶ Per Resolution No. 427, the Commission must approve any expenses from the SAWPA fund to pay for these types of expenses.

\$ 500 – 4,000	At least one quote received
4,001 – 15,000	At least two quotes received
15,001 – 34,999 (or greater if not a Public Works Contract under Section 3.4)	At least three quotes received

# Cost Sharing with Riverside County Parks

- ▶ SAWPA staff will procure and manage the consultant (SAWPA has a more streamlined process),
- ▶ Riverside County Parks has the ability to cost share,
- ▶ Both agencies can determine cost share depending on costs provided by consultants, and
- ▶ A similar consultant scope in 2018 cost approximately \$7,000.



# Recommendation

Authorize SAWPA staff to seek quotes from various firms to assist SAWPA and the Riverside County Park and Open-Space District to improve the Santa Ana River Mitigation Bank structure.

**More Information if Needed**

# Arundo Management & Habitat Restoration Fund Budget

Budget Category	FYE 2020	FYE 2021
Salaries	\$11,976	\$17,301
Benefits	\$5,463	\$7,837
Indirect Costs	\$18,021	\$26,089
Consulting	\$6,000	\$75,000
Offsite Meetings	\$800	\$800
Shipping/Postage	\$500	\$500
Program Expenses	\$10,000	\$150,000
<b>Total</b>	<b>\$52,760</b>	<b>\$277,527</b>

Note: Current total fund balance (due to mitigation bank credit sales) is approximately \$950,000.

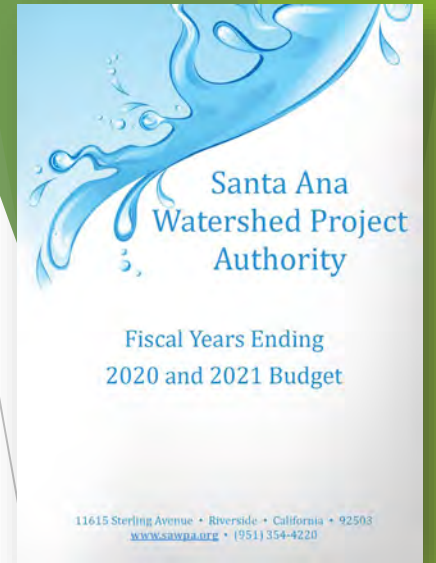

# Proposition 84 IRWM Drought Grant Overview

Ian Achimore | Senior Watershed Manager

January 19, 2021 | Commission Meeting

Item 6.F.





# Project Agreement (PA) 22 Committee

- ▶ Composed of the five SAWPA member agency general managers.
- ▶ Created October 7, 2014 to implement regional water use efficiency projects.
- ▶ Advised by SAWPA and the PA 22 Advisory Workgroup:
  - ▶ SAWPA member agencies,
  - ▶ Municipal Water District of Orange County, and
  - ▶ Rancho California Water District.



# Drought Grant Projects/Tasks

Project 1: Conservation Based Reporting Tools and Rate Structure Implementation



Web Tool



Water Rates

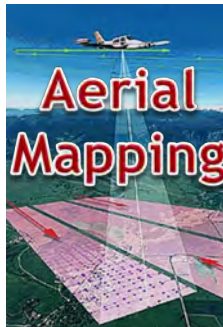

Aerial Mapping

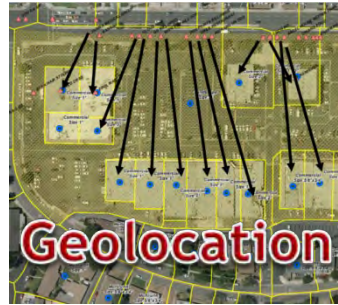

Geolocation

Project 2: High Visibility Turf Removal and Retrofit



Turf Removal

**\*Tasks**

# Multi-IRWM Region Project

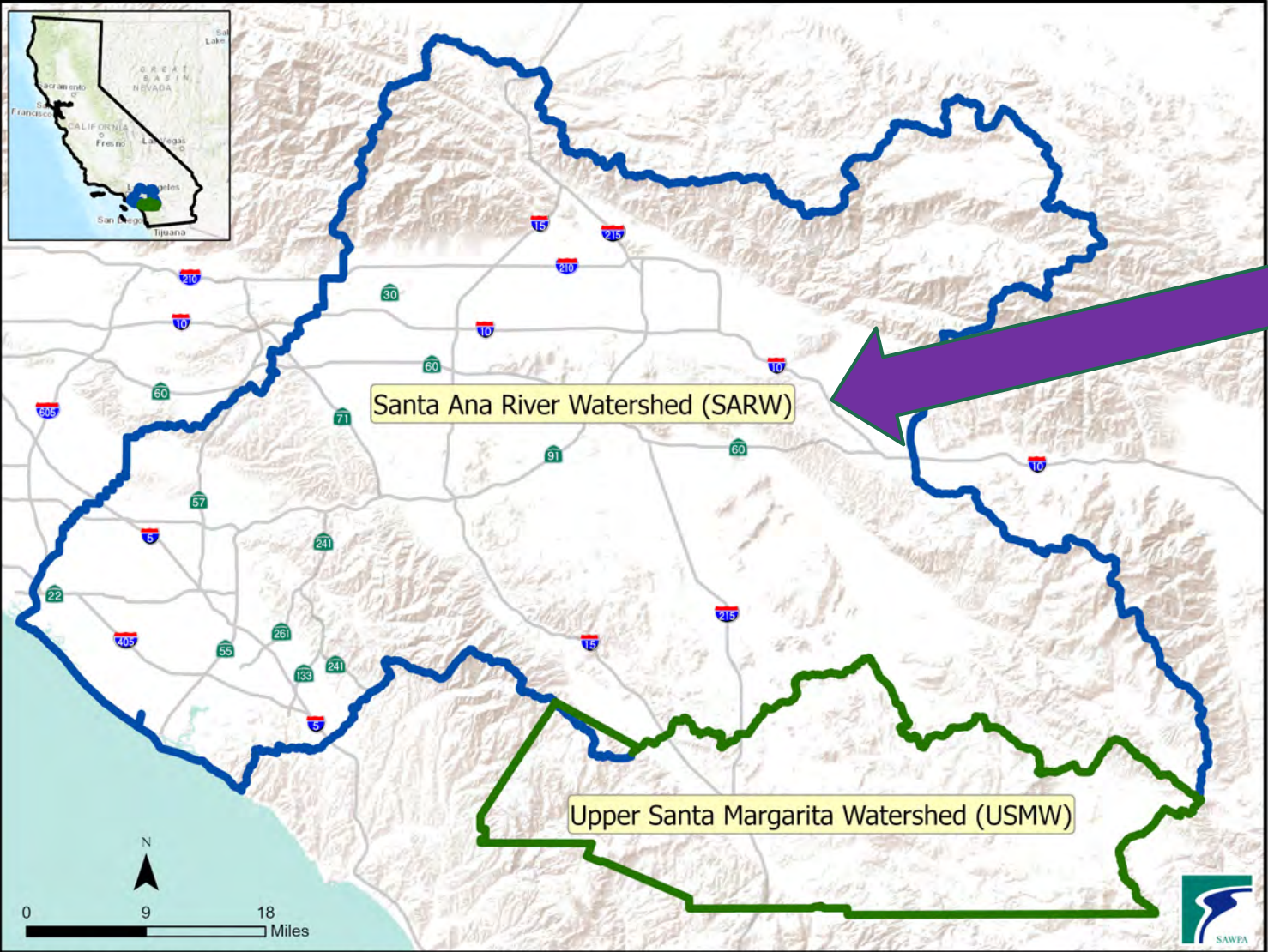



# Drought Grant Budget



	Project 1			Project 2		
	SARW	USMW	Total	SARW	USMW	Total
Grant Amount	\$6,330,066	\$105,610	\$6,435,676	\$5,426,934	\$997,500	\$6,424,434
Required Match	NA*	NA*	NA*	\$6,125,292	\$926,241	\$7,051,533
Additional Match	NA*	NA*	NA*	\$8,437,783	\$201,624	\$8,639,407
<b>Grand Total</b>	<b>\$6,330,066</b>	<b>\$105,610</b>	<b>\$6,435,676</b>	<b>\$19,990,009</b>	<b>\$2,125,365</b>	<b>\$22,115,374</b>

\*Not applicable (NA) as all match was included in Project 2.





# Drought Grant Schedule

Governor Declares Drought Emergency



January 2014

Governor Lifts Emergency



April 2017



July 2015



Drought Grant Signed

December 2020



Drought Grant Complete

# Drought Conditions - Annual Average Precipitation in SAR Watershed

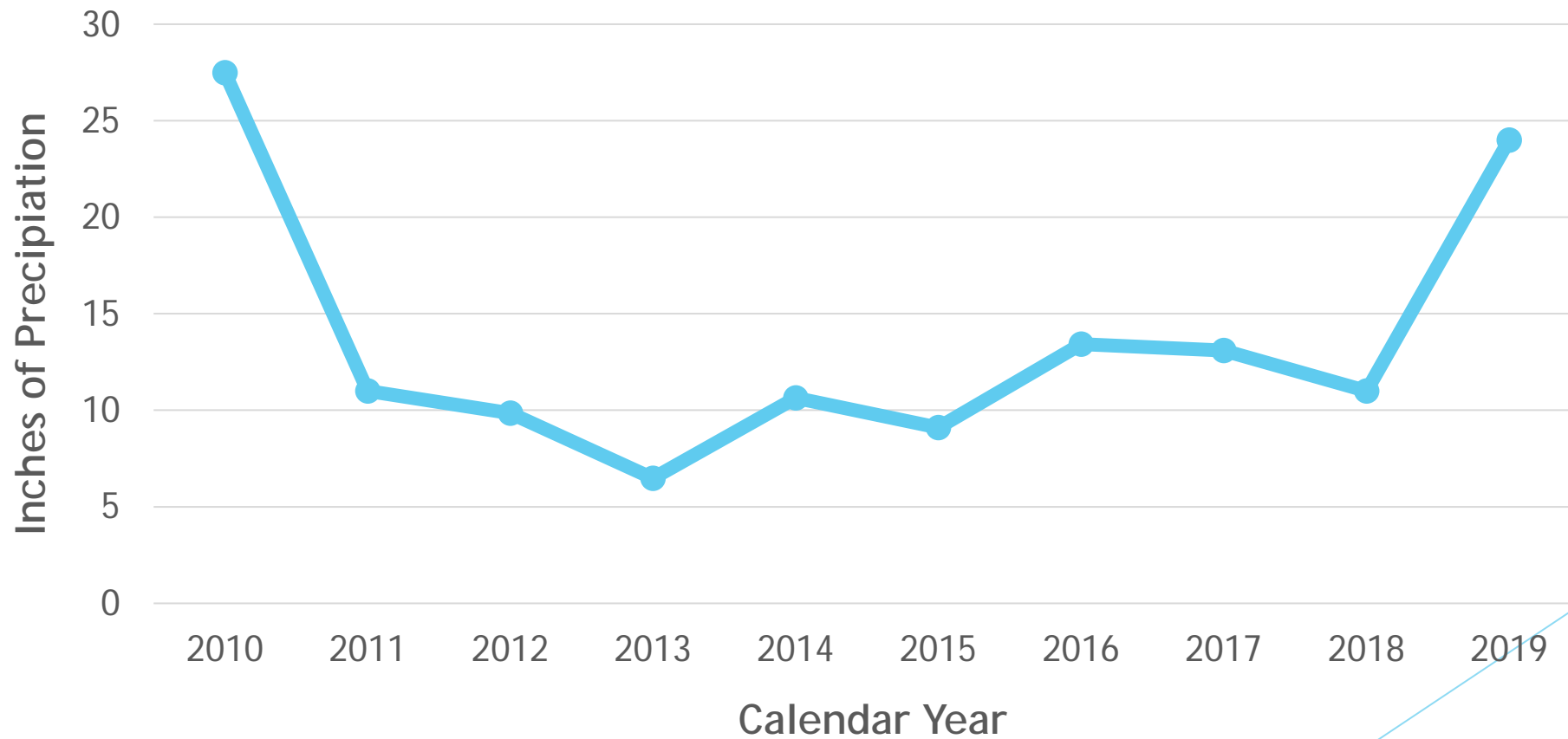

# Project 1: Conservation Based Reporting Tools and Rate Structure Implementation



**Web Tool**



**Water Rates**

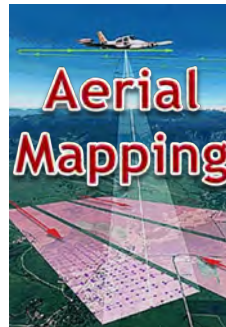

**Aerial Mapping**

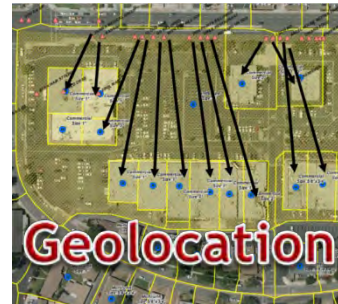

**Geolocation**

**\*Tasks**



# Drought Grant Benefits - Project 1

Project Component	Benefit Type	Benefit Amount
Web-Based Decision Support Tool	Retail Agencies	11
Conservation-Based Rates Analyzed	Retail Agencies	9
Conservation-Based Rates Adopted	Retail Agencies	3
Aerial Mapping Data Developed	Square Miles	2,473
Recipients of Aerial Mapping Data	Retail/Wholesale/Flood Agencies	35
Web-Viewer Users for Aerial Mapping Data	Retail/Wholesale Agencies	10
Recipients of Geolocation Landscape Measurements	Retail Agencies	17

Project 1 was able to directly benefit **42 separate water agencies** throughout the SARW and USMW. Note that some agencies received benefits in multiple components.





# Water Savings Benefits – Project 1 In Acre Feet (AF)

Component Included in Application With Quantitative Benefit	Total Savings Goal Included in Application	Total Actual Savings	Difference from Application (-/+)	Total \$ Quantification Actual Savings**
Decision Support Tool	3,236	892	-2,344	\$673,747
Conservation Rates*	4,821	16,268	+11,447	\$12,282,429
<b>Total</b>	<b>8,057</b>	<b>17,160</b>	<b>+9,103</b>	<b>\$12,956,176</b>

\*No data included from one rate agency, City of Chino, as its conservation-based rates have not been implemented for one year as of December 15, 2020. Thus actual savings may be larger than shown.

\*\*An estimate using Metropolitan Water District of Southern California Tier 1 Full Service Untreated 2020 volumetric rate (\$755/AF).

# Decision Support Tool

## ▶ Scope:

- ▶ Single family residential customers were able to view their usage in comparison to an efficiency budget.
- ▶ The comparison between a customer's budget and their usage was available through both hardcopy mailers as well as a web-based application.
- ▶ To view the budgets in the application, the costumers were required to download the application at no cost.

Retail Agency Participating	Subscription Start Date	Subscription End Date
Brea City	1/16/2017	1/16/2018
Fullerton City	1/12/2016	1/11/2017
Loma Linda City	5/24/2016	5/23/2017
Newport Beach City	12/27/2016	12/28/2017
Ontario City	1/10/2017	1/11/2018
Rialto City	11/21/2016	11/20/2017
Tustin City	6/9/2016	6/8/2017
Eastern Municipal WD	1/1/2017	1/1/2018
Monte Vista WD	11/4/2015	11/3/2017
West Valley WD	4/7/2016	4/7/2017
Yorba Linda WD	11/27/2016	11/26/2017

Total savings from all agencies = 892 Acre Feet

# Aerial Mapping

## ► Scope:

- Use high resolution 3-inch aerial imagery captured in Summer 2015.
- Imagery used to classify urban irrigable and irrigated areas by parcel and retail water agency.
- Data available (no cost share required) for SAWPA member agencies, retailers and other entities with a water-nexus.

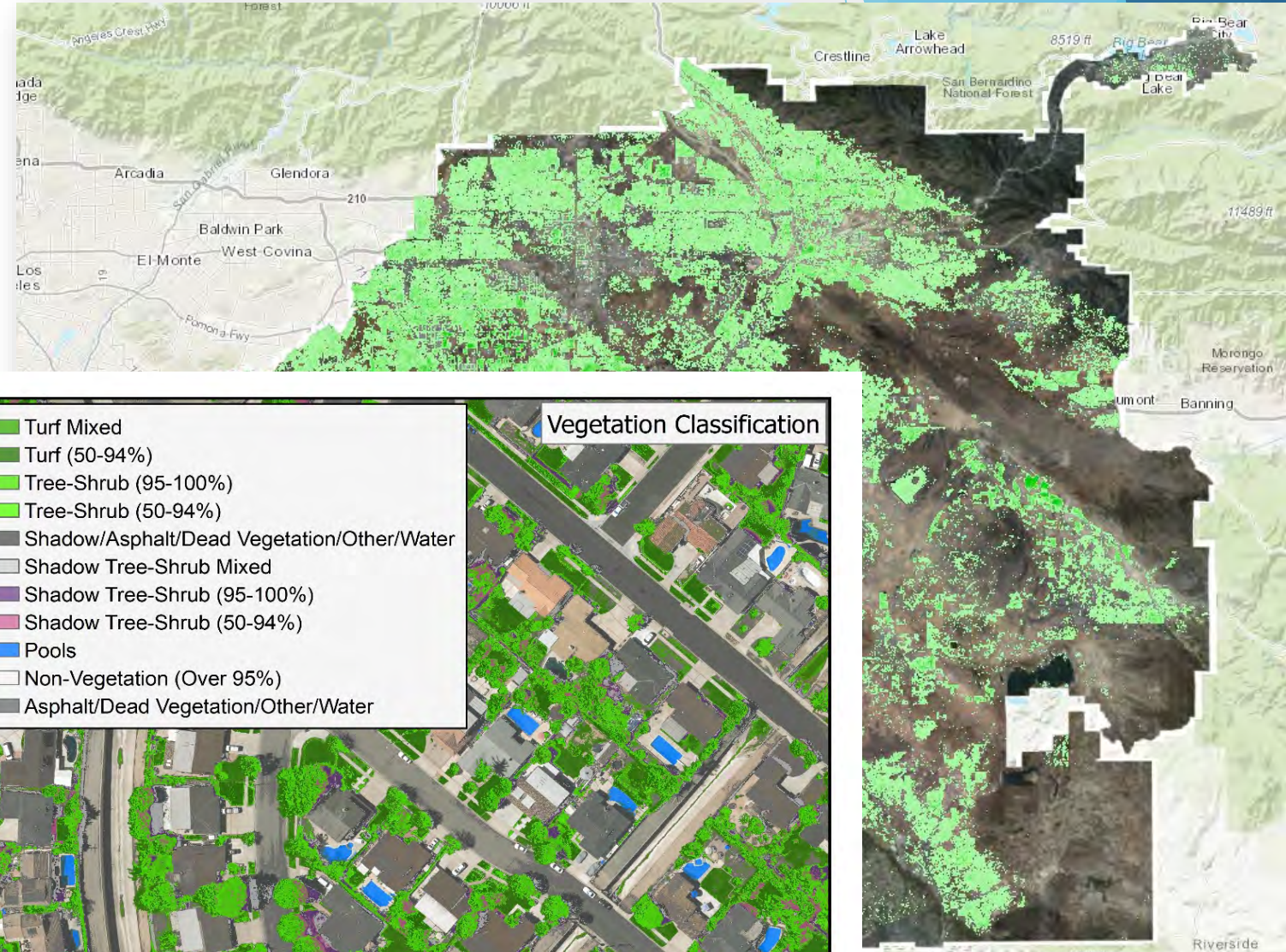



# Geolocation of Landscape Measurements

- ▶ Scope
  - ▶ Consultant worked with 17 interested retail water agencies on geolocating landscape measurements.
  - ▶ Geolocation done by isolating measurements into specific Meter Service Areas (boundaries) for each customer, such as shop-units within a mall.
  - ▶ This additional step is often needed for customers who don't have a single parcel (or address).



Legend

- ▲ Customer Address
- Meter Service Area Point
- ▨ Meter Service Area



# Conservation-Based Rates

## Sample Customer with Less Vegetation

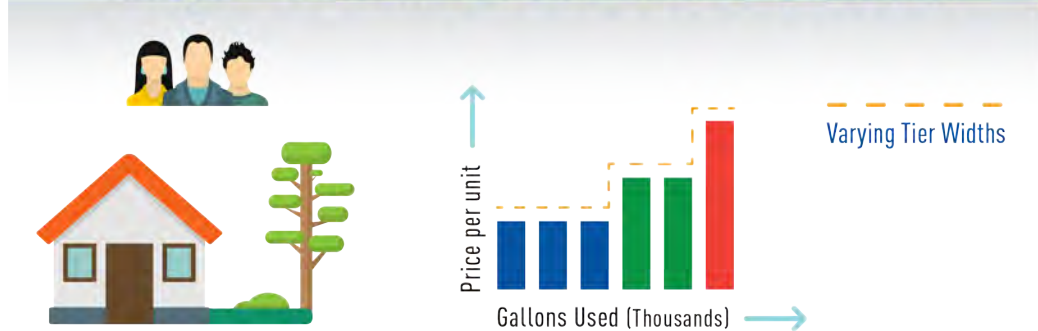

## Sample Customer with More Vegetation

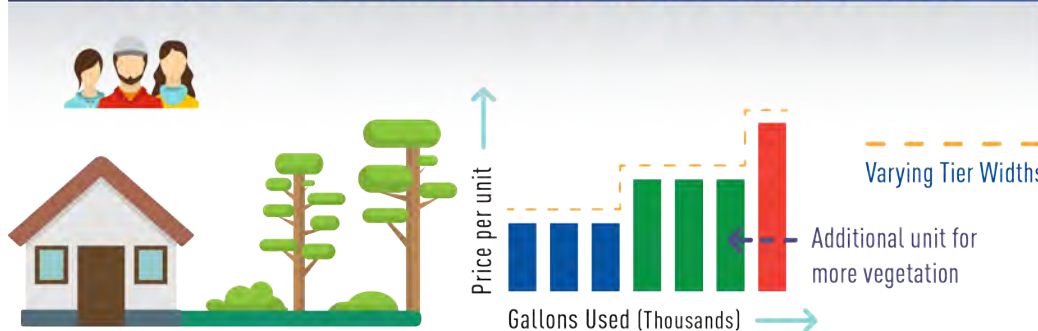

Retail Partner	Adopted Conservation Rates
Chino City	Yes
Chino Hills City	Yes
Cucamonga Valley Water District	No
East Valley Water District	Yes
Garden Grove City	No
Hemet City	No
Rialto City	No
San Jacinto City	No
Tustin City	No

Total savings from agencies that adopted rates = 16,368 Acre Feet

# Other Benefits from Project 1

- A. Several video-recorded workshops in 2015 aimed at elected officials, general managers and CFOs.;
- B. Several SAWPA webpages designed by CV Strategies in 2018 created to communicate the Project and its benefits to interested retail water agencies.
- C. A water rate model analysis developed in 2015 by Dr. Kenneth Baerenklau, economics professor at UC Riverside;
- D. A 2017 local newspaper op-ed article about the benefits of conservation-based rates by former Commission chair and SBVMWD Director Susan Longville; and
- E. Seven two-page factsheets developed by CV Strategies and SAWPA staff in 2017 created to help retail water agencies with targeted messaging to their customers.



## Project 2: High Visibility Turf Removal and Retrofit



# Project 2 Organization Structure

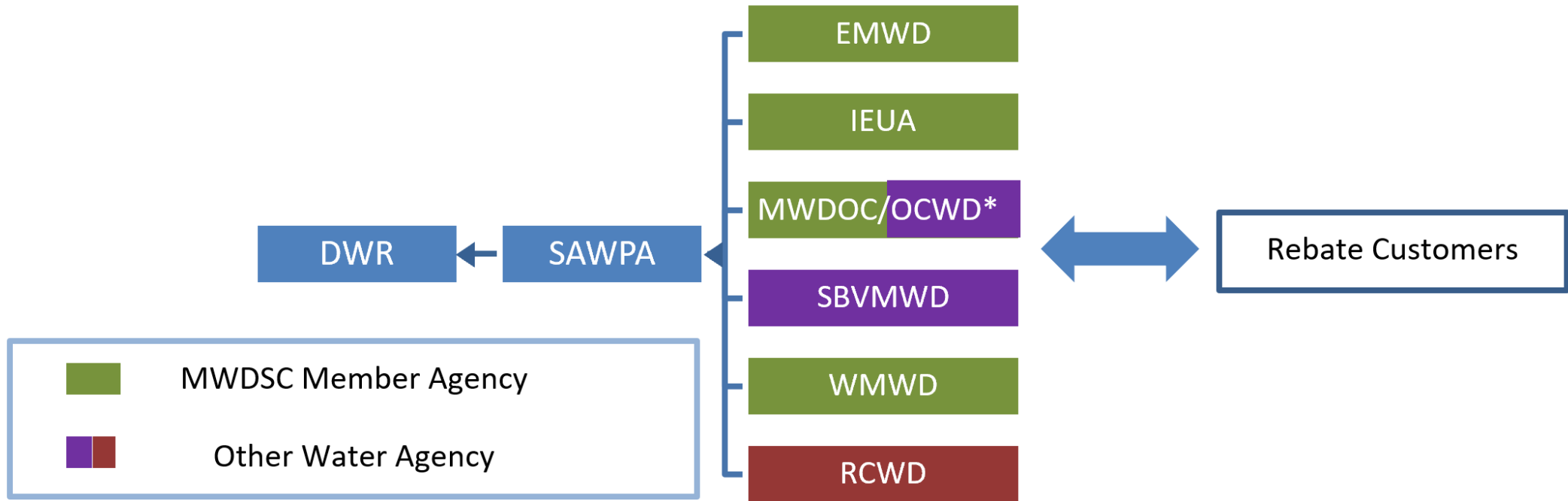

\*SAWPA had grant contract with OCWD, and OCWD subsequently had sub-contract with MWDOC who rebated the customers.



# Map of Water Agencies Involved in Project 2

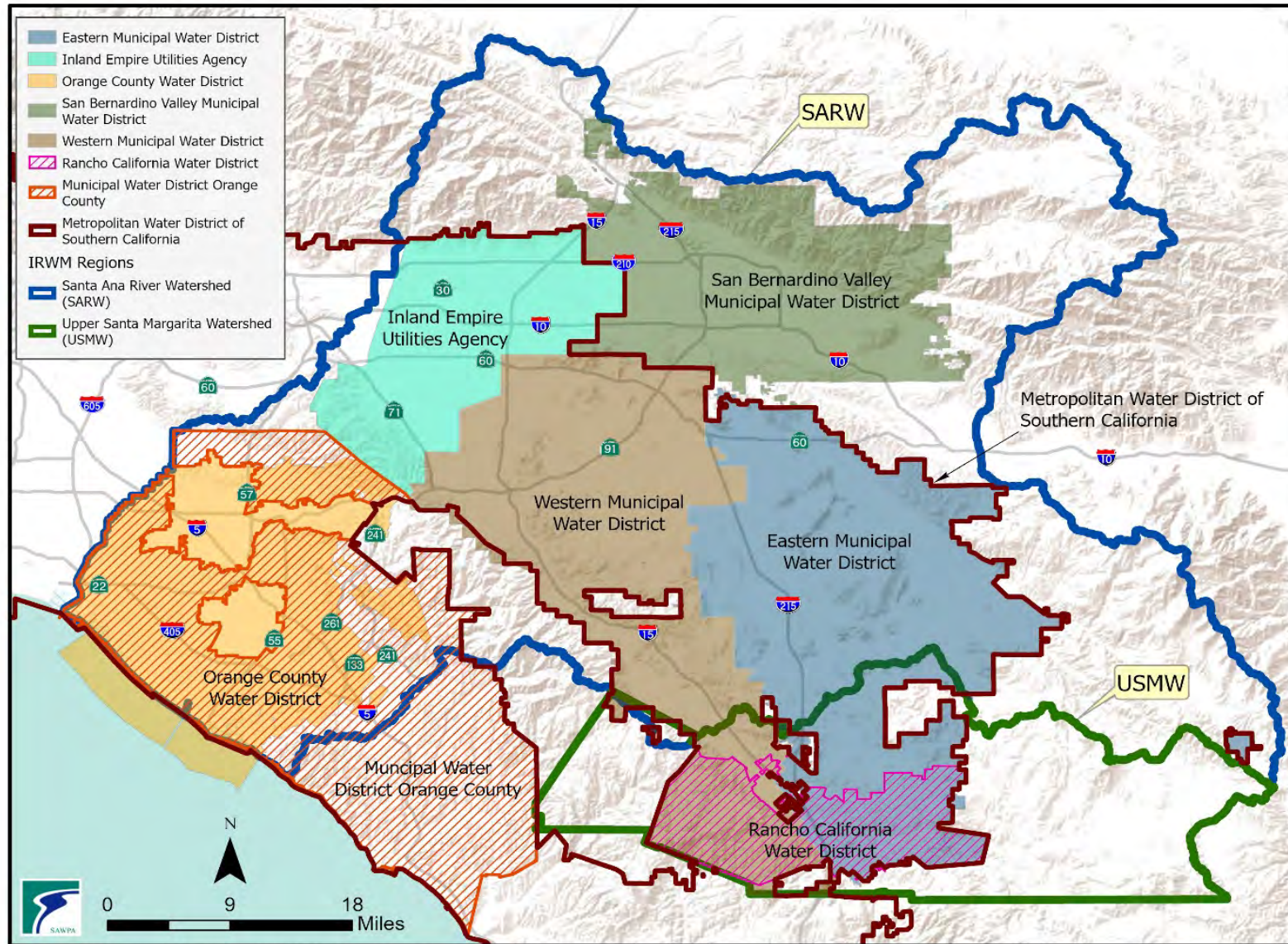



# Water Savings Benefits - Project 2

## In Acre Feet Per Year (AFY) and Square Feet (SF)

IRWM Region	Total Square Feet Turf Removed (Amount from Grant Application)	Total Square Feet Turf - Actual Removed	Percent of Turf Removal Increase (Square Feet)	Annual Actual Savings (Acre Feet Per Year*)	Annual \$ Quantification of Savings**
<b>SARW</b>	4,000,000	8,074,885	202%	1,090	\$823,222
<b>USMW</b>	950,000	1,573,730	166%	212	\$160,060
<b>Total</b>	<b>4,950,000</b>	<b>9,648,615</b>	<b>195%</b>	<b>1,302</b>	<b>\$983,282</b>

\*An estimate of 44 gallons saved per square foot per year (based on water conservation analysis).

\*\*An estimate using Metropolitan Water District of Southern California Tier 1 Full Service Untreated 2020 volumetric rate (\$755/AF).

# Benefits by Partner Agency

Partner Agency (IRWM Region)	Turf Removal (Square Feet)	Associated Water Savings (Acre Feet Per Year)
EMWD (SARW)	2,143,121	289
EMWD (USMW)	432,027	58
IEUA (SARW)	2,531,032	342
OCWD/MWDOC (SARW)	1,224,196	165
SBVMWD (SARW)	851,241	115
WMWD (SARW)	1,325,295	179
WMWD (USMW)	52,809	7
RCWD (USMW)	1,088,894	147
<b>Grand Total</b>	<b>9,648,615</b>	<b>1,302</b>
SARW SubTotal	8,074,885	1,090
USWM SubTotal	1,573,730	212



**Project in EMWD service area – Whispering Pines HOA – before/after conversion**



**Project in MWDOC/OCWD Service Area – Brea Civic Center, City of Brea – before/after conversion**





# Questions

The background of the slide is white with abstract blue geometric shapes on the right side. These shapes include overlapping triangles and polygons in various shades of blue, ranging from light sky blue to a dark navy blue. The shapes are layered, creating a sense of depth and movement.